

NOTE:
 PROTECTIVE COVERS ARE FACTORY INSTALLED TO THE TOP AND BOTTOM OF THE DRIVE TO MEET IP20 & NEMA TYPE 1 REQUIREMENTS, RESULTING IN AN AMBIENT TEMPERATURE RATING OF 104F(40C). REMOVE THESE COVERS WHEN OPERATING THE DRIVE WITHIN A PANEL TO OBTAIN THE MAXIMUM SURROUNDING AIR TEMPERATURE RATING OF 122F(50C). REMOVING THESE COVERS RESULTS IN AN ENCLOSURE RATING OF IP00.

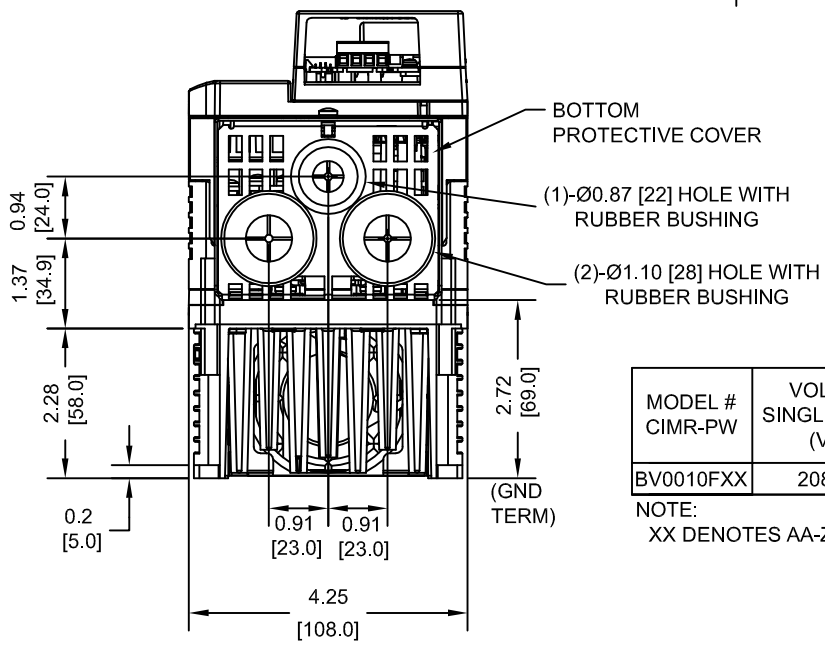
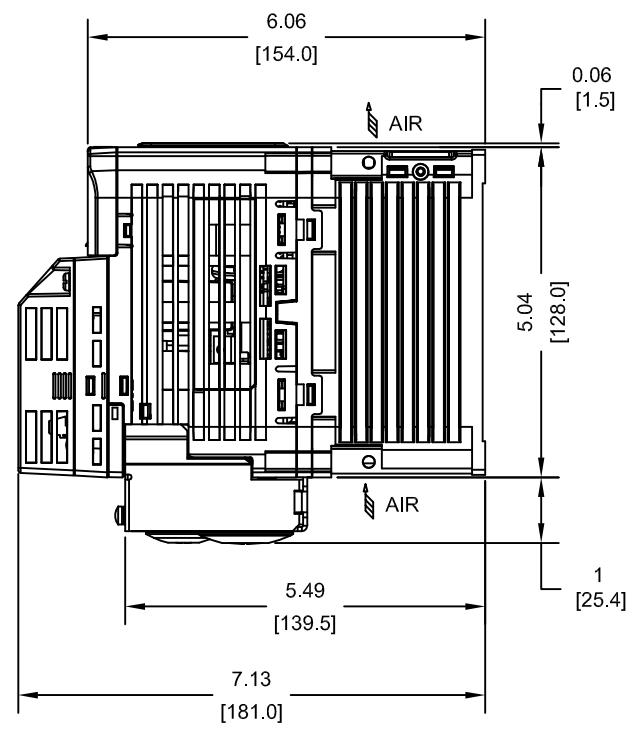
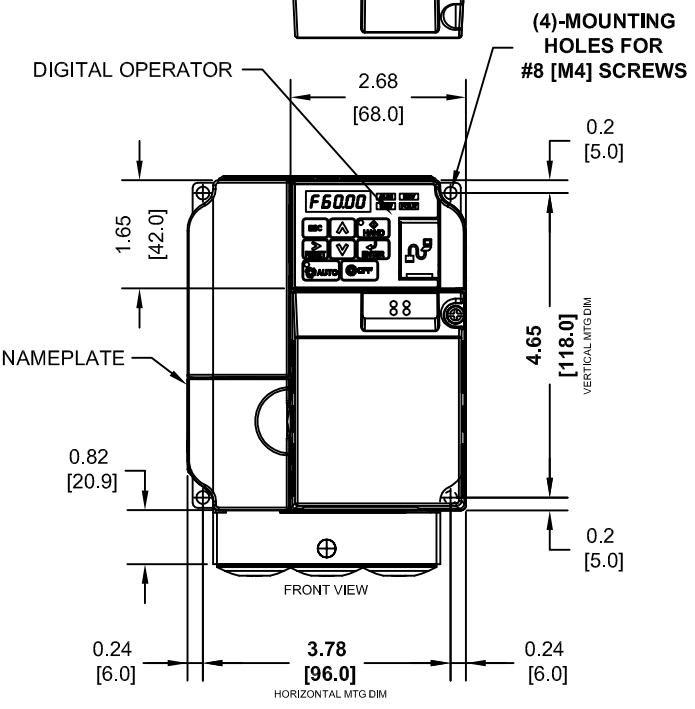

MODEL # CIMR-PW	VOLTAGE SINGLE PHASE (VAC)	OUTPUT CURRENT (A)	WEIGHT LBS (Kg)	HEAT LOSS (W) (Fc=2kHz)		
				INT	EXT	TOT
BV0010FXX	208/240	9.6	4.4 (2.0)	29.8	51.7	81.5

NOTE:
 XX DENOTES AA-ZZ

INT=INTERNAL COMPONENTS
 EXT=EXTERNAL HEATSINK
 TOT=TOTAL

FOR ADDITIONAL DETAILS AND SPECIFICATIONS, CONSULT MANUAL

TOLERANCES / REFERENCES:		<p>YASKAWA</p> <p>THIS DOCUMENT AND INFORMATION CONTAINED IN IT ARE CONFIDENTIAL, AND CANNOT BE COPIED OR DISCLOSED IN WHOLE OR IN PART WITHOUT THE EXPRESS WRITTEN CONSENT OF YASKAWA AMERICA, INC.</p>	DRAWN: J. MATTAS	DATE: 10-28-14	TITLE: IQ PUMP MICRO DIMENSION DRAWING FRAME SIZE 10 NEMA TYPE 1 ENCLOSURE BV0010F	
			CHECKED: J. PIOTROWSKI	DATE: 10-31-14		
			TECH: J. BORJA	DATE: 10-31-14		
			APPROVED: J. CAIRO	DATE: 11-18-14		
UNITS: IN[mm]	SCALE: 1:3	ORIGINAL DESIGN: -	DATE: -	SIZE: A	REVISION: R00	PAGE: 1 of 4
				DRAWING #: DD.IQPM.FR10.N1		

TERMINAL AND WIRING DETAILS (SCALE 1:2)

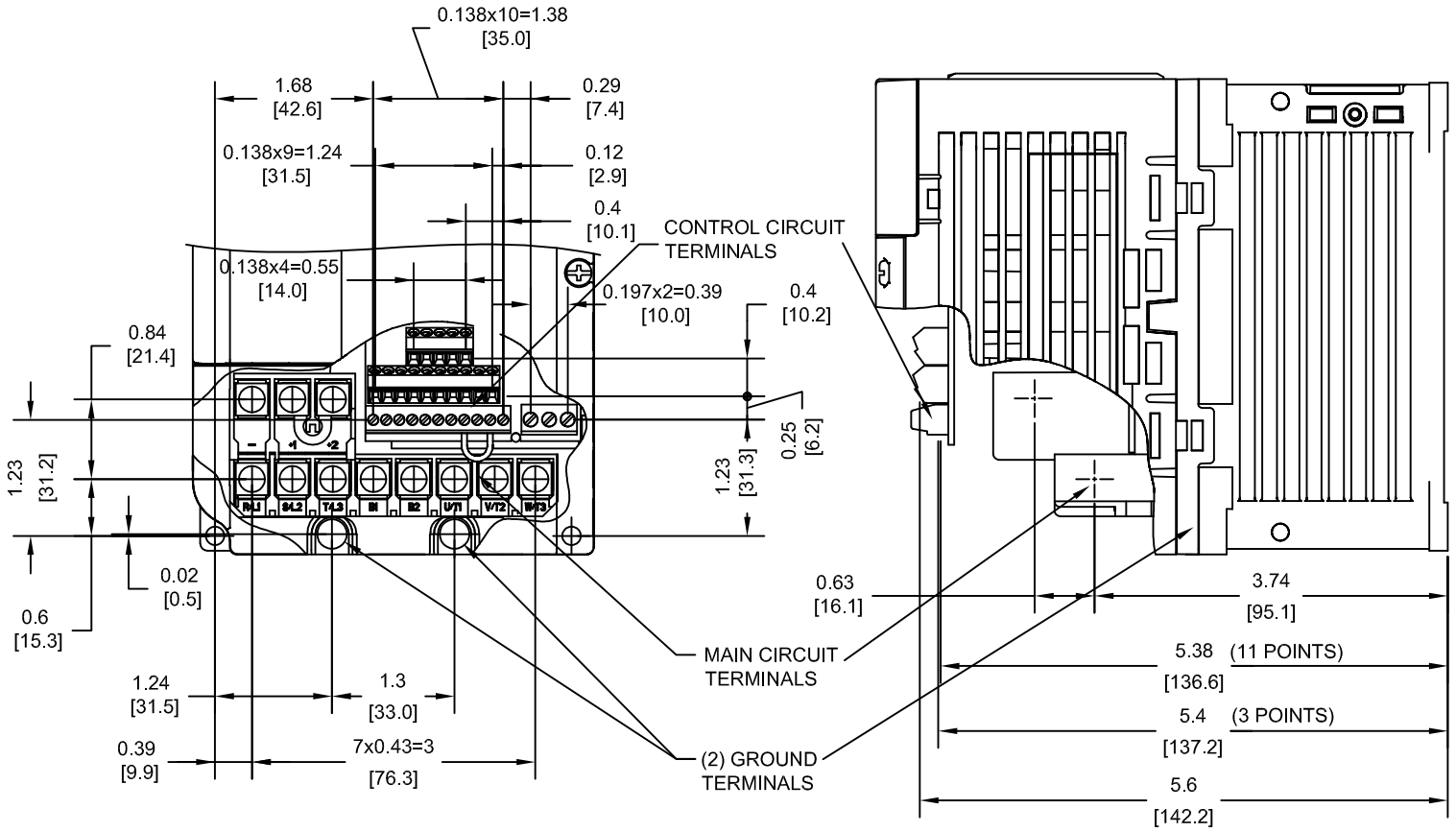

TERMINAL AND WIRE SPECIFICATIONS FOR
MAIN CIRCUIT AND GROUND

MODEL #	TERMINAL SCREW	CLAMPING TORQUE lb.in.(N.m.)	WIRE RANGE AWG(mm ²)
CIMR-PW	M4	10.6 TO 13.3 (1.2 TO 1.5)	22-10 (0.33-5.5)
BV0010F	M4	10.6 TO 13.3 (1.2 TO 1.5)	22-10 (0.33-5.5)

NOTE: RATINGS APPLY TO BOTH FACTORY AND FIELD WIRING
REFER TO APPLICABLE CODES FOR PROPER WIRE TYPE AND SIZE

FOR ADDITIONAL DETAILS AND SPECIFICATIONS, CONSULT MANUAL

TOLERANCES / REFERENCES:		<p>THIS DOCUMENT AND INFORMATION CONTAINED IN IT ARE CONFIDENTIAL, AND CANNOT BE COPIED OR DISCLOSED IN WHOLE OR IN PART WITHOUT THE EXPRESS WRITTEN CONSENT OF YASKAWA AMERICA, INC.</p>	DRAWN: J. MATTAS DATE 10-28-14	TITLE: IQ PUMP MICRO DIMENSION DRAWING FRAME SIZE 10 NEMA TYPE 1 ENCLOSURE BV0010F		
			CHECKED: J. PIOTROWSKI DATE 10-31-14	SIZE A	REVISION R00	PAGE 2 of 4
			TECH: J. BORJA DATE 10-31-14	APPROVED: J. CAIRO DATE 11-18-14	DRAWING #: DD.IQPM.FR10.N1	
UNITS: IN[mm]	SCALE: BY VIEW		ORIGINAL DESIGN: -	DATE -		

MINIMUM INSTALLATION CLEARANCES (SCALE 1:4)

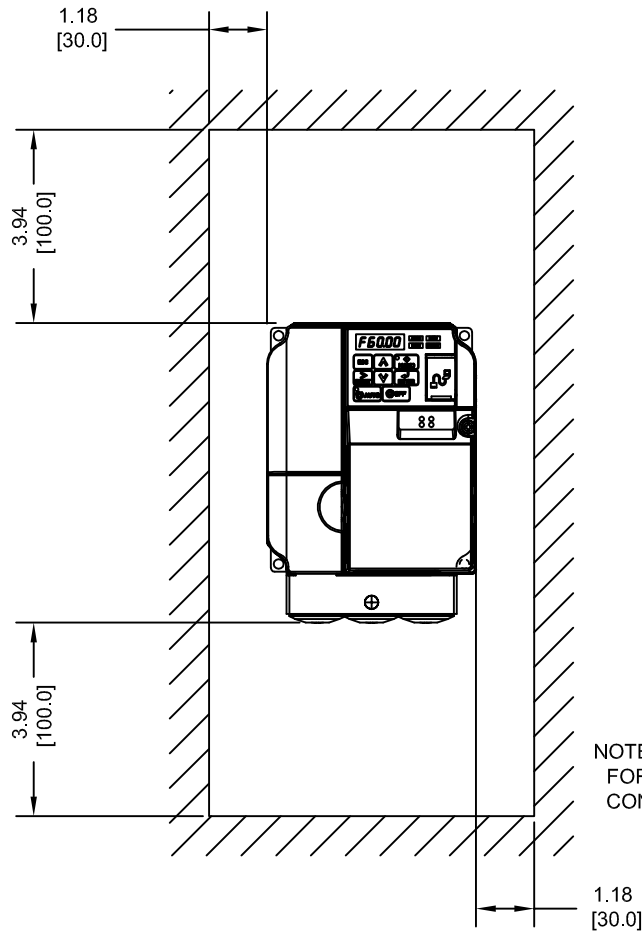

NOTE:
FOR SIDE-BY-SIDE MOUNTING
CONSULT MANUAL

PANEL CUTOUT FOR EXTERNAL HEATSINK
MOUNTING CONFIGURATION (SCALE 1:4)

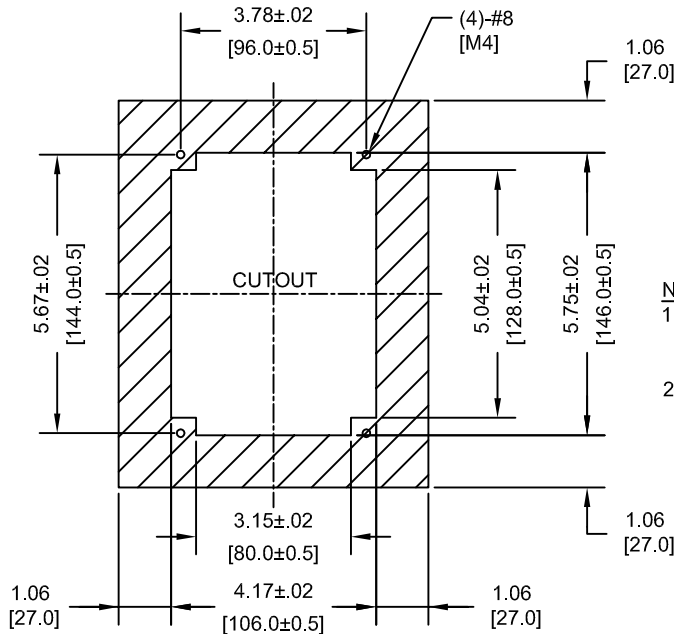

NOTES:
1. EXTERNAL HEATSINK
CONFIGURATION REQUIRES
MOUNTING KIT
2. EXPOSED HEATSINK
RECOMMENDED CLEARANCE
D=2.76" MINUS PANEL THICKNESS

TOLERANCES / REFERENCES:		<p>THIS DOCUMENT AND INFORMATION CONTAINED IN IT ARE CONFIDENTIAL, AND CANNOT BE COPIED OR DISCLOSED IN WHOLE OR IN PART WITHOUT THE EXPRESS WRITTEN CONSENT OF YASKAWA AMERICA, INC.</p>	DRAWN: J. MATTAS	DATE 10-28-14	TITLE: IQ PUMP MICRO DIMENSION DRAWING	
UNITS: IN[mm]			SCALE: BY VIEW	CHECKED: J. PIOTROWSKI	DATE 10-31-14	FRAME SIZE 10
				TECH: J. BORJA	DATE 10-31-14	NEMA TYPE 1 ENCLOSURE
				APPROVED: J. CAIRO	DATE 11-18-14	BV0010F
			ORIGINAL DESIGN:	DATE -	DRAWING #: DD.IQPM.FR10.N1	
				SIZE A	REVISION R00	
					PAGE 3 of 4	

24V OPTION KIT (SCALE 1:2)

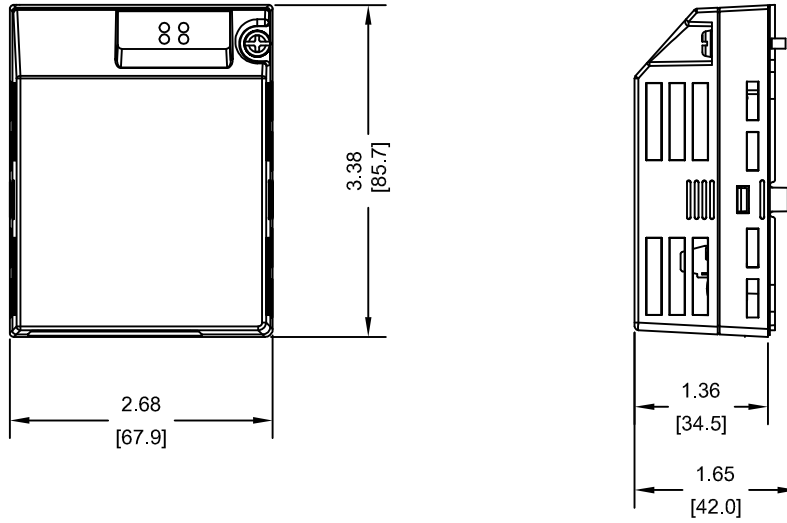

24V OPTION KIT (SCALE 1:2)
COVER REMOVED

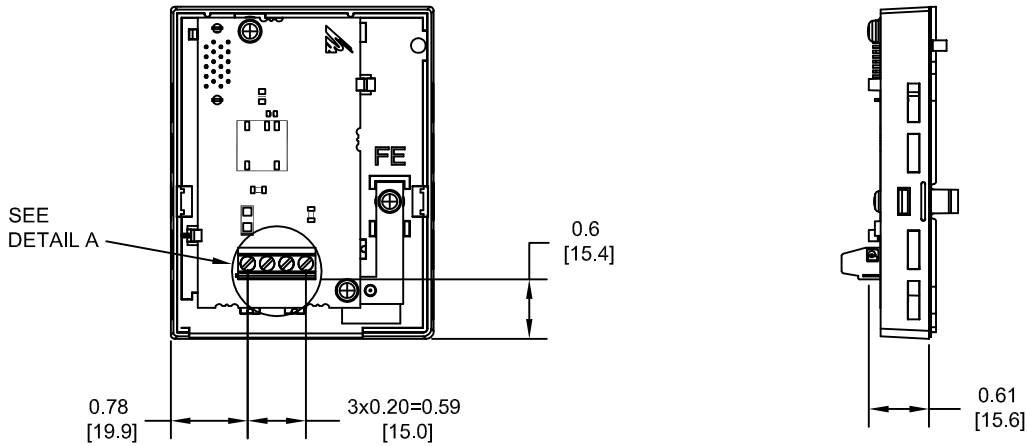

DETAIL A (SCALE 2:1)

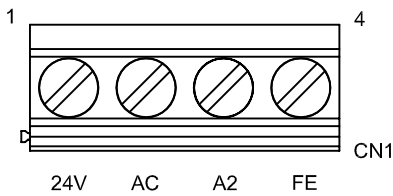

24V OPTION KIT - SPECIFICATIONS

TERMINAL SCREW	CLAMPING TORQUE lb.in.(N.m.)	WIRE RANGE AWG(mm ²)	OPTION KIT WEIGHT LBS(Kg)
M3	4.4 TO 5.3 (0.5 TO 0.6)	30-14 (0.05-2.0)	0.1 (0.05)

TOLERANCES / REFERENCES:		 THIS DOCUMENT AND INFORMATION CONTAINED IN IT ARE CONFIDENTIAL, AND CANNOT BE COPIED OR DISCLOSED IN WHOLE OR IN PART WITHOUT THE EXPRESS WRITTEN CONSENT OF YASKAWA AMERICA, INC.	DRAWN: J. MATTAS	DATE 10-28-14	TITLE: IQ PUMP MICRO DIMENSION DRAWING FRAME SIZE 10 NEMA TYPE 1 ENCLOSURE BV0010F	
UNITS: IN[mm]			SCALE: BY VIEW	CHECKED: J. PIOTROWSKI		DATE 10-31-14
			APPROVED: J. CAIRO	DATE 11-18-14		SIZE A
			ORIGINAL DESIGN: -	DATE -	REVISION R00	
					PAGE 4 of 4	
					DRAWING #: DD.IQPM.FR10.N1	